

4500 4501

NON INSULATED

INSULATED



25 GAUGE

PREMIUM COMMERCIAL/INDUSTRIAL STEEL DOORS

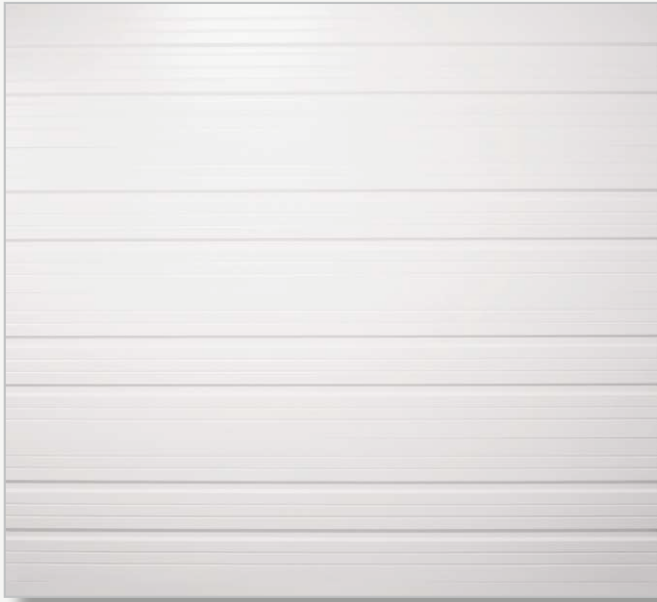

4500 4501

PAINT

1.0
MIL

PAINT

1.0
MIL

EFFICIENCY

6.85
R-VALUE

INTERIOR

VINYL
SKIN

Constructed of top quality materials with pebble embossed finish, designed for each application and engineered for years of dependable operation.

Configure your door on our website at

www.DoorLinkMfg.com

PREMIUM COMMERCIAL/INDUSTRIAL STEEL DOORS

4500 / 4501 STANDARD FEATURES

DOOR SECTIONS

Door sections are galvanized steel and have a 2" thickness. Panels are nominal 24 gauge pebble grain embossed. Sections have tongue and groove meeting rails. Interior flange of panel has a hemmed edge. Panels are formed with two deep ribs and six small grooves. Center and end stiles are 17 gauge galvanized steel. Open sides of stiles have rolled edges. Stiles are mechanically fastened and adhesive bonded to panel to act as an integral structure of the section. Center stiles are shaped to match the profile of the panel.

GLAZING

Options of 24" x 12" or 24" x 4" windows are available. Optional Series 8000 Full View sections can be substituted for steel sections.

INSULATION

Model 4501 doors are insulated with polystyrene insulation. Interior face of insulation is covered with a vinyl protective skin. Insulation R value is 6.85.

TRACK

Galvanized track system is 2" or 3" depending on door size and weight and to be bracket or angle mounted as required.

HARDWARE

Hinges and brackets are made from galvanized steel. Commercial duty rollers are standard.

SPRING COUNTERBALANCE

Springs are oil tempered helical wound and stress relieved torsion springs mounted on a cross header shaft supported by bearing brackets. Springs are calculated for 10,000 door cycles. 25K, 50K, or 100K cycles are optional. Cables are galvanized aircraft quality with a minimum 7 to 1 safety factor.

FINISH

1.0 mil paint system includes .25 mil rust inhibiting primer and .75 mil top coat that resists fading and chalking while providing consistent color from panel to panel.

WEATHERSTRIP

Bottom section has a replaceable U type bottom astragal retained by an extruded aluminum retainer. Optional jambs and header weather-stripping is available.

LOCK

Lock is interior mounted slide lock.

OPERATION

Operation to be manual push up, chain hoist, or electric motor.

WIND LOAD

Consult factory for available wind load rated options.

SIZES AVAILABLE

DOOR WIDTH PANELS WIDE SECTION HEIGHTS: 18" 21" 24"

UP to 9'2"	□ □
9'3" to 12'2"	□ □ □
12'3" to 17'2"	□ □ □ □
17'3" to 18'2"	□ □ □ □ □

COLORS



BROCHURE COLOR
MAY VARY FROM
ACTUAL PRODUCT.

CONSTRUCTION

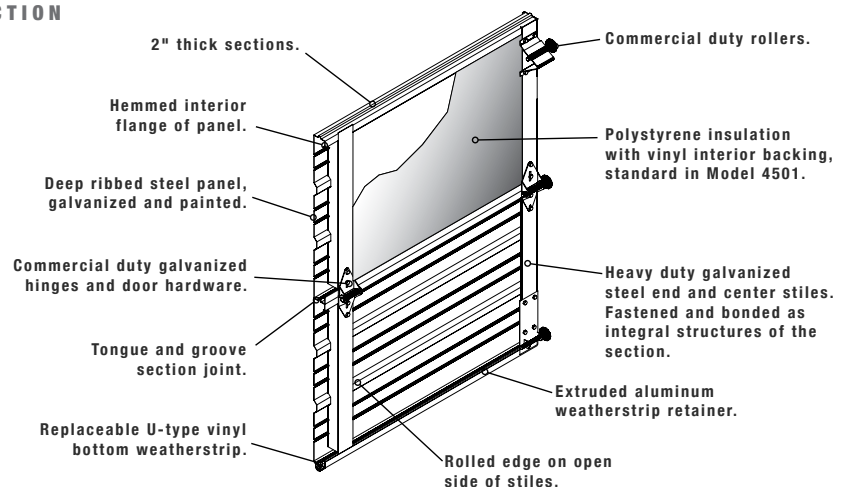

Your Local Authorized Dealer:



To view this
product
online:

